

SK1-632D Catch Basin w/ Polymer Concrete Riser & Base Spec Sheet



SK1-632D
part no. 97931 (S100K)



Side

Front

Side

Front

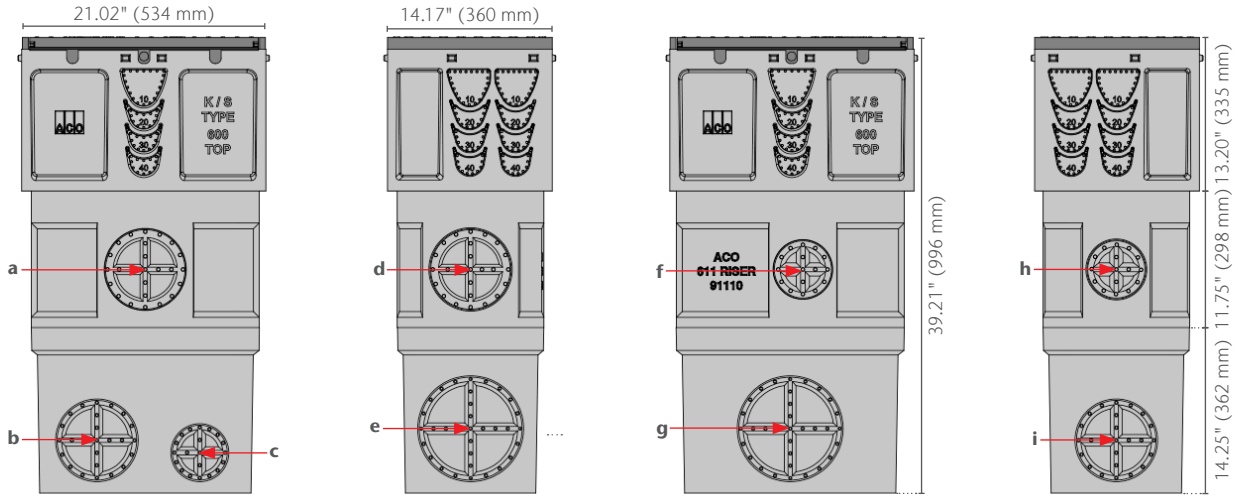

Underside

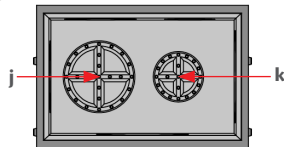

Catch Basin Outlet	Size (SCH 40)	Invert in	GPM	CSF
a	6.00"	22.95	547	1.26
b	6.00"	37.65	721	1.66
c	4.00"	37.71	325	0.75
d	6.00"	22.95	547	1.26
e	8.00"	37.64	1262	2.90
f	4.00"	21.95	547	1.26
g	8.00"	37.64	1262	2.90
h	4.00"	21.95	547	1.26
i	6.00"	37.65	721	1.66
j	6.00"	39.20	767	1.76
k	4.00"	39.20	341	0.78

Note: These are pipe flow rates at specified outlets, NOT channel flow rates. Catch basin flow rates are listed without a trash bucket—using a trash bucket reduces flow.

Trash Bucket

included with the SK1-632D

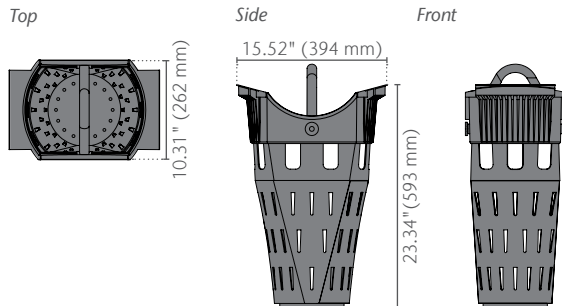

Riser

included with the SK1-632D (part no. 91110)

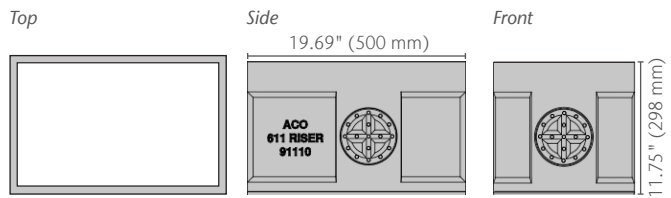

Note: Adding a riser will alter the outflow rates of the bases detailed above.



SK1-632D Catch Basin w/ Polymer Concrete Riser & Base Spec Sheet



Product Name	Part No.	Volume* gal	Weight lbs
SK1-632D Catch Basin w/ Polymer Concrete Riser & Base	97931	25.9	231.0
Series 611 Polymer Concrete Riser	91110	8.9	45.0

*Volume is up to grate seat and without trash bucket.

Specification Summary

General

The catch basin shall be ACO Drain® SK1-632D Catch Basin, comprising of a top section, trash bucket, riser and base as manufactured by ACO, Inc. or similar approved

Riser

Riser can be useful between polymer concrete top unit and base. Use of riser is determined by access and local building codes.

Grates

Grates shall be specified. See separate ACO Spec Info grate sheets for details. After removal of grates there shall be uninterrupted access to the catch basin to aid maintenance. Accepts all 0.5 m ACO S100K PowerLok® grates or S100K 4-Bolt grates.

Installation

The trench drain/catch basin system shall be installed in accordance with the manufacturer's installation instructions and recommendations.

Materials

The catch basin top section, base and riser shall be manufactured from polymer concrete with the minimum properties as follows:

- Compressive strength: 13,053 psi
- Flexural strength: 3,191 psi
- Water absorption: 0.07%
- Resistant to dilute acid and alkali
- Frost-proof
- Salt-proof

The nominal clear opening shall be 14.17" (360 mm) wide by 21.02" (534 mm) long. Type SK1-632D catch basin assembly has overall depth of 39.21" (996 mm). Polymer concrete top units shall incorporate a cast in a ductile iron frame manufactured with drillouts for channel connection and have a wall thickness of at least 0.59" (15 mm). Top units shall have horizontal cast in anchoring key features on the outside to ensure maximum mechanical bond to the surrounding bedding material and pavement surface. The trash bucket shall be a polypropylene plastic molding.



200,000 lb Proof Load



EN1433 Load Class F
202,328 lbs – 4,177 psi

ACO, Inc.

© January 2026 ACO, Inc.

All reasonable care has been taken in compiling the information in this document. All recommendations and suggestions on the use of ACO products are made without guarantee since the conditions of use are beyond the control of the company. It is the customer's responsibility to ensure that each product is fit for its intended purpose and that the actual conditions of use are suitable. ACO, Inc. reserves the right to change products and specifications without notice.

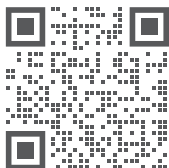

info@acousa.com
www.acousa.com

